

# Millimeter-Wave Fresnel-Zone Plate Lens and Antenna

Hristo D. Hristov, *Senior Member, IEEE*, and Mathieu H. A. J. Herben, *Senior Member, IEEE*

**Abstract**—A new variety of millimeter-wave Fresnel-zone plate lens with enhanced focusing quality is described. Each full-wave zone of the lens is divided into four quarter-wave subzones, which are covered by dielectric rings having equal thickness but different permittivities. More practical equations are derived for the radii of the zones, and for the thickness of the lens by taking into account the angle of incidence of the electromagnetic wave.

A Fresnel-zone plate antenna (FZPA) consisting of a quarter-wave lens and a scalar feed is developed and analysed theoretically. Equations for the aperture field and far field are derived using multiple ray tracing through dielectric plates and vectorial Kirchhoff diffraction theory, respectively. It is demonstrated that the proposed transmissive-type FZPA has an aperture efficiency of more than 50% in the 60 GHz frequency band. This computed efficiency agrees with the measured overall efficiency reported by other researchers for an X-band quarter-wave reflector-type FZPA.

## I. INTRODUCTION

THE FRESNEL-ZONE plate lens (FZPL) is a focusing and imaging device invented and studied by Fresnel more than 150 years ago. For a long time its applications have been mainly restricted to optical systems. Since the Fresnel zone principle works at any frequency, the corresponding lens can also be used to focus millimeter-waves. The simplest (low-cost) FZPL, consisting of alternate transparent and reflecting (or absorbing) rings, has rather poor focusing properties and the aperture efficiency of the corresponding lens antenna is less than 15%.

To increase the focusing quality of the lens, Wiltse proposed to replace the opaque zones by phase-reversing dielectric ones, and thus a half-wave FZPL was introduced [1]–[3]. Based on this phase-reversing dielectric lens, transmissive-type antennas have been developed and examined [3]–[5], [9], [10]. For these antennas an aperture efficiency of about 30% is typical. From a commercial point of view, however, an efficiency of 50–60% is desirable for microwave aperture antennas.

In the present paper a new FZPL with enhanced focusing quality will be described and analysed. Each full-wave Fresnel zone is divided into four quarter-wave subzones which are covered by dielectric rings having equal thickness but

different, properly chosen permittivities. It appears that this lens configuration has much better focusing properties and compared to the grooved FZPL [3] it has the advantage that its front and back surfaces are flat.

More precise and practical equations are derived for the radii of the zones, and for the thickness of the lens by taking into account the angle of incidence of the spherical wave originating from the feed.

The planar quarter-wave FZPL will be used to design a transmissive-type dielectric-ring Fresnel-zone plate antenna (FZPA) with a scalar feed. Equations are derived for the aperture field and far fields of this antenna using multiple ray tracing through dielectric plates and vectorial Kirchhoff diffraction theory, respectively, [6], [9], [10].

The idea behind the multidielectric transmissive-type FZPL is not a new one [3], but to the authors' knowledge there are no publications on this particular lens design and its electromagnetic analysis. In principle, the working mechanism is similar to that used in some reflector-type FZPA's, proposed and examined recently by Guo and Barton [7], [8], [12]. The specific quarter-wave FZPL which will be analysed has a diameter of 150 mm and a focal length of 132 mm. The lens is illuminated by a scalar feed horn and the complete antenna operates in a frequency band of 54–68 GHz. Computer calculations indicate that this FZPA has an aperture efficiency of about 52% and a directive gain of 36.8 dBi at a frequency of 62.1 GHz. The computed efficiency agrees with the measured overall efficiency reported by Guo and Barton for an X-band quarter-wave reflector-type FZPA [12].

## II. PLANAR LENS DESCRIPTION

In principle, the FZPL does not transform smoothly the incident spherical wave from the feed into an outgoing plane wave. The lens is a stepwise phase-transformer and in the case of the quarter-wave FZPL the maximum phase deviation in the antenna aperture equals  $90^\circ$ .

Fig. 1 shows a sketch of the proposed quarter-wave FZPL. Each full-wave Fresnel zone is divided into four quarter-wave subzones. The central subzone is open and the other three subzones are covered by dielectric rings with different permittivities. The next full-wave zones have similar arrangements.

To accomplish a quarter-wave stepwise phase-correction with a planar dielectric lens, the relative permittivities of the dielectric rings which give the desired phase shifts of  $\Delta\Phi_t = 0^\circ$ ,  $\Delta\Phi_t = 90^\circ$ ,  $\Delta\Phi_t = 180^\circ$ , and  $\Delta\Phi_t = 270^\circ$  (or  $-90^\circ$ ) were found to be  $\epsilon_{r1} = 1$ ,  $\epsilon_{r2} = 6.25$ ,  $\epsilon_{r3} = 4$ , and  $\epsilon_{r4} = 2.25$ , respectively. This follows from the computed 'multiple'

Manuscript received February 27, 1995; revised July 7, 1995. H. D. Hristov was supported by the European COST Telecommunications Secretariat (Commission of the European Communities, Brussels) Research Contract CIPA 3510 CT926503/1993 for the analysis and design of Fresnel-zone antennas at Eindhoven University of Technology.

H. D. Hristov is with the Department of Radiotechnics, Faculty of Electronics, Technical University of Varna, 9010 Varna, Bulgaria.

M. H. A. J. Herben is with the Telecommunications Division, Faculty of Electrical Engineering, Eindhoven University of Technology, 5600 MB Eindhoven, The Netherlands.

IEEE Log Number 9415481.

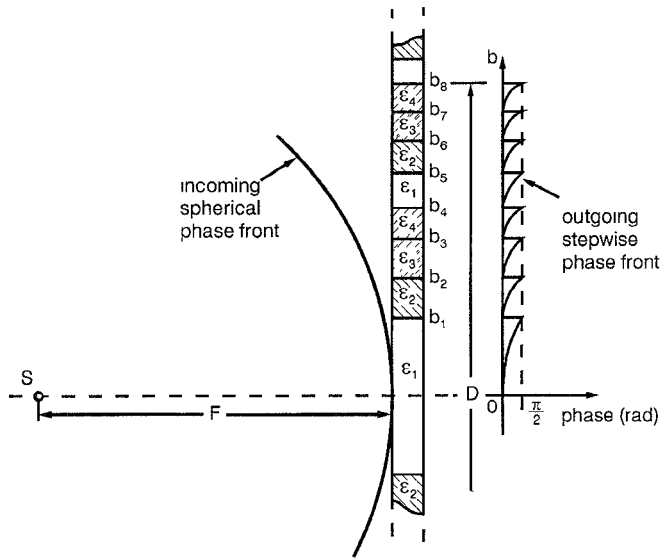

Fig. 1. Planar quarter-wave Fresnel-zone plate lens as phase transformer.

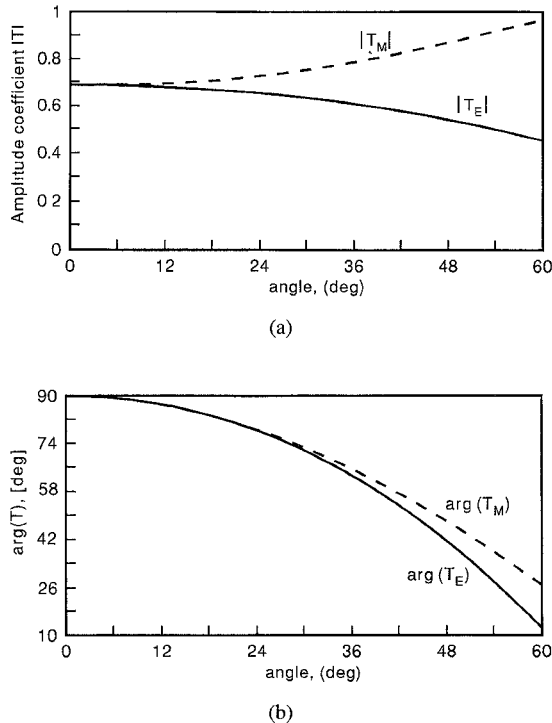

Fig. 2. Amplitude (a) and phase (b) of the transmission coefficients for a dielectric plate with  $\epsilon_r = 6.25$  as a function of the angle incidence. Solid line: perpendicular ( $E$ ) polarization; dashed line: parallel ( $M$ ) polarization.

transmission coefficients of dielectric plates with the above mentioned relative permittivities and with the thickness of the ideal dielectric phase-shifter, i.e.,  $d = \lambda_0/2$  for  $\epsilon_r = 4$  [9, 10]. Here,  $\lambda_0$  is the design wavelength in free-space, and 'multiple' indicates that the internal reflections within the dielectric plate are taken into account [9].

Figs. 2, 3, and 4 show that the above mentioned phase shifts are realized only for normal wave incidence. Furthermore, it follows from these figures that the magnitude of the transmission coefficients  $|T_{M,E}|$  for  $\epsilon_r = 4$  and  $\epsilon_r = 2.25$  are very

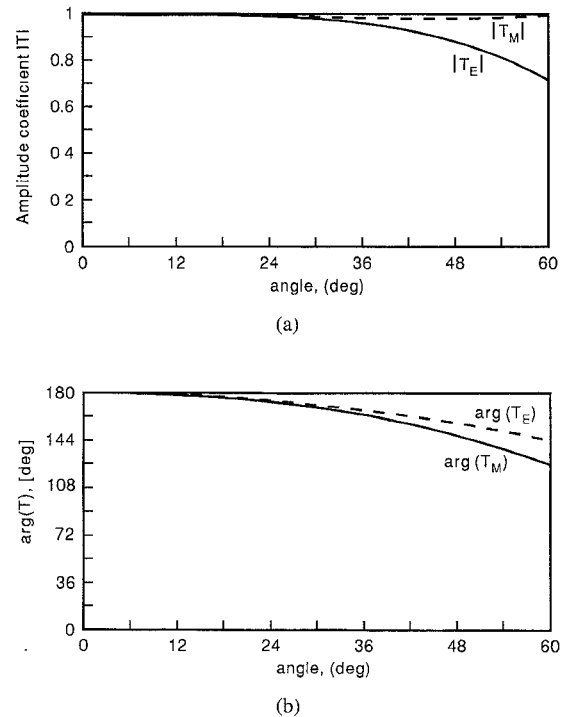

Fig. 3. Amplitude (a) and phase (b) of the transmission coefficients for a dielectric plate with  $\epsilon_r = 4.00$  as a function of the angle of incidence. Solid line: perpendicular ( $E$ ) polarization; dashed line: parallel ( $M$ ) polarization.

near to 1 for all angles of incidence, while for  $\epsilon_r = 6.25$ ,  $|T_{M,E}| \approx 0.7$ , which means that the second subzone transmits only about 50% of the incident power. This will of course decrease the focusing quality of the quarter-wave FZPL, and the aperture efficiency of the corresponding FZPA.

### III. PLANAR FRESNEL-ZONE PLATE LENS DESIGN

Fig. 5 shows the ray tracing through a dielectric FZPL consisting of phase-correcting dielectric rings. At a given dielectric constant  $\epsilon_r$ , design wavelength  $\lambda_0$ , and focal distance  $F$ , the basic lens dimensions, being the zone radii  $b_m$  and lens thickness  $d$ , have to be calculated. In the case of an ideal very thin planar lens the Fresnel zone radii are obtained from the following approximate equation

$$b_m = \sqrt{2mq\lambda_0 F + (mq\lambda_0)^2} \quad (1)$$

where  $m$  is the zone number and  $q$  is the phase-correction factor ( $q = 1$  for the classical FZPL,  $q = 0.5$  for the half-wave FZPL, and  $q = 0.25$  for the quarter-wave FZPL).

The real planar lens has a nonzero thickness  $d$ , which is not included in the equation for the zone radii. In the case of a lens with an open first zone, the phase reference value of zero degrees is assumed to be the phase at point  $O''$ , i.e., at the center of the equivalent circular radiating aperture. In this case, the radius of the open zone can be found from (1) after replacing  $F$  by  $F + d$ . For the dielectric rings, however, it is more likely to use (1) without any change. Our analyses have shown that the following modified equation is a good

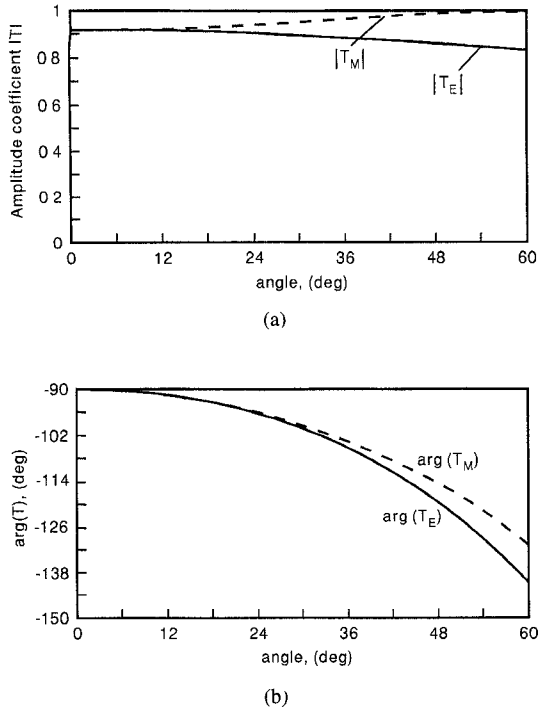

Fig. 4. Amplitude (a) and phase (b) of the transmission coefficients for a dielectric plate with  $\epsilon_r = 2.25$  as a function of the angle of incidence. Solid line: perpendicular ( $E$ ) polarization; dashed line: parallel ( $M$ ) polarization.

compromise for the calculation of the radii of all Fresnel zones

$$b_m = \sqrt{2mq\lambda_0 \left(F + \frac{d}{2}\right) + \left(\frac{m\lambda_0}{2}\right)^2}. \quad (2)$$

The thickness  $d$  of the phase-reversing dielectric plate is usually calculated by the following equation [2], [3]

$$d = \frac{\lambda_0}{2(\sqrt{\epsilon_r} - 1)} \quad (3)$$

which is valid only for normal wave incidence. But normal incidence never occurs for the dielectric FZPL with an open first zone, because for that configuration there is oblique wave incidence for all dielectric rings. Thus, to determine the lens thickness, one should examine the phase shift of the dielectric rings for oblique wave incidence.

The phase variation due to the presence of the dielectric rings, which is called the insertion phase difference between the refracted ray  $rQ'Q''r_2$  and the free space direct ray  $rQ'Q'''r_1$  (Fig. 6), can be found approximately as follows

$$\Delta\Phi_t \approx k_0[(l_2\sqrt{\epsilon_r} + r_2) - (\Delta l + \Delta r + r_1)] \quad (4)$$

where  $k_0 = 2\pi/\lambda_0$ ,  $l_2 = d/\cos\psi_t$ ,  $r_2 = r_1 + \Delta r$ , and  $\Delta l = d\cos(\psi - \psi_t)/\cos\psi_t$ .

Here, the effects of the multiple internal reflections and the polarization dependence of the transmission are neglected.

Thus, the phase difference  $\Delta\Phi_t$  can be written as

$$\Delta\Phi_t = \frac{k_0 d}{\cos\psi_t} [\sqrt{\epsilon_r} - \cos(\psi - \psi_t)]. \quad (5)$$

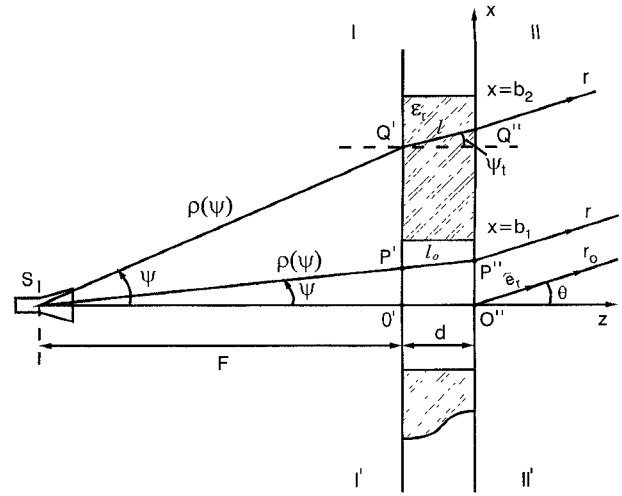

Fig. 5. Ray tracing through the Fresnel-zone plate lens with dielectric and transparent zones.

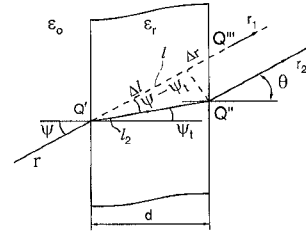

Fig. 6. Ray tracing through a dielectric plate.

Using Snell's second (refraction) law  $\cos\psi_t = \sqrt{\epsilon_r - \sin^2\psi}/\sqrt{\epsilon_r}$ , and after some trigonometric manipulations, (5) becomes

$$\Delta\Phi_t = \frac{2\pi}{\lambda_0} d (\sqrt{\epsilon_r - \sin^2\psi} - \cos\psi). \quad (6)$$

In the general case,  $\Delta\Phi_t = 2\pi q$  and the lens thickness  $d$  is found by

$$d = \frac{q\lambda_0}{\sqrt{\epsilon_r - \sin^2\psi} - \cos\psi}. \quad (7)$$

For the phase-reversing FZPL ( $q = 0.5$ ) and normal ray incidence ( $\psi = 0^\circ$ ), (7) reduces to (3). It is evident from (7) that the plate thickness essentially depends on the angle of incidence of the incoming wave.

In Table I values of the lens thickness  $d$  for several angles of incidence  $\psi$ ,  $\epsilon_r = 4$ ,  $q = 0.5$ , and  $\lambda_0 = 5$  mm (design frequency = 60 GHz) are given. For the axially symmetric FZPA, the incidence angle generally does not exceed  $45^\circ$ , i.e.,  $\psi_{\max} = \text{atan}(b_{\max}/F)$ , with  $b$  being the radius of the dielectric ring and  $F$  the focal length of the lens. On the other hand, the minimum angle of incidence from which the refraction into the dielectric rings starts is  $\psi_{\min} = \text{atan}(b_1/F)$ . Therefore, in calculating the lens thickness it is acceptable to choose for the angle of incidence its average value  $\psi_{\text{av}} = (\psi_{\min} + \psi_{\max})/2$ .

TABLE I  
THICKNESS OF PHASE-REVERSING DIELECTRIC  
PLATE FOR SEVERAL ANGLES OF INCIDENCE

Angle of incidence $\psi$ (deg)	0	20	40	60	80
Lens thickness $d$ (mm)	2.50	2.42	2.22	1.92	1.60

#### IV. QUARTER-WAVE FRESNEL-ZONE PLATE ANTENNA

##### A. Field Distribution in Lens Aperture

The axially symmetric patterns of scalar feeds are frequently approximated by the following function

$$G_f(\psi, n) = \begin{cases} 2(n+1) \cos^n \psi & \text{for } 0 \leq \psi \leq \frac{\pi}{2} \\ 0 & \text{for } \psi > \frac{\pi}{2} \end{cases} \quad (8)$$

Furthermore, it is often assumed that the scalar feed has Huygens source polarization properties, so that the vectorial field at the input plane  $I - I'$  (point  $Q'$  in Fig. 5) is given by

$$\vec{E}_f(\psi, \xi, n) = C_f \sqrt{G_f(\psi, n)} \frac{e^{-jk\rho(\psi)}}{\rho(\psi)} \cdot \hat{e}_f(\psi, \xi) \quad (9)$$

where

$$C_f = \sqrt{(P_f Z_0)/(2\pi)} \quad (10)$$

and

$$\hat{e}_f(\psi, \xi) = -\cos \xi \cdot \hat{e}_\psi + \sin \xi \cdot \hat{e}_\xi \quad (11)$$

Here  $P_f$  is the power radiated by the feed,  $Z_0 = 120\pi$  is the free space wave impedance,  $\hat{e}_f(\psi, \xi)$  is the polarization unit-vector and  $k = 2\pi/\lambda$  is the wave number. From geometrical considerations (Fig. 5) it follows that

$$\rho(\psi) = \frac{F}{\cos \psi} \quad (12)$$

The incident ray  $\rho(\psi)$  of the locally-plane wave continues as a refraction ray through a dielectric ring with a relative permittivity  $\epsilon_r$  and thickness  $d$ , and in the point  $Q''$  it gives rise to an electric field  $\vec{E}_d(\psi, \xi, n)$ . The transmission through the dielectric ring for the two linear orthogonal polarizations is characterized by so-called multiple transmission coefficients  $T_M$  (for the parallel polarization) and  $T_E$  (for the perpendicular polarization). At the output or aperture plane  $II - II'$ , the field intensity can be expressed in the following form

$$\vec{E}_d(\psi, \xi, n) = C_f \sqrt{G_f(\psi, n)} \frac{e^{-jk\rho(\psi)}}{\rho''(\psi)} \vec{P}_d(\psi, \xi) \quad (13)$$

where

$$\vec{P}_d(\psi, \xi) = -T_M \cos \xi \cdot \hat{e}_\psi + T_E \sin \xi \cdot \hat{e}_\xi \quad (14)$$

is a polarization vector,  $1/\rho''(\psi)$  is an equivalent divergence factor, and  $\hat{e}_\psi$  and  $\hat{e}_\xi$  are the  $\psi$  and  $\xi$  unit vectors, respectively. The transmission coefficients  $T_M$  and  $T_E$  are given by

$$T_{M,E} = S_d \frac{1 - R_{1M,E}^2}{1 - R_{1M,E}^2 S_d^2 S_a} \quad (15)$$

where

$$S_d = e^{-jk\sqrt{\epsilon_r}l(\psi)} \quad (16)$$

and

$$S_a = e^{j2kl(\psi) \sin \psi \sin \psi_t} \quad (17)$$

are phase factors, and  $R_{1M,E}$  equals the reflection coefficient  $R_{1M}$  or  $R_{1E}$ , for the  $M$ - and  $E$ -polarization, respectively, at the interface plane  $II - II'$ . It is known that  $R_{1M}$  and  $R_{1E}$  are given by

$$R_{1M} = \frac{\epsilon_r \cos \psi - \sqrt{\epsilon_r - \sin^2 \psi}}{\epsilon_r \cos \psi + \sqrt{\epsilon_r - \sin^2 \psi}} \quad (18)$$

$$R_{1E} = \frac{\cos \psi - \sqrt{\epsilon_r - \sin^2 \psi}}{\cos \psi + \sqrt{\epsilon_r - \sin^2 \psi}} \quad (19)$$

After substitution of (15) in (14),  $\vec{P}_d(\psi, \xi)$  becomes

$$\vec{P}_d(\psi, \xi) = S_d \vec{P}'_d(\psi, \xi) = S_d (-T'_M \cos \xi \cdot \hat{e}_\psi + T'_E \sin \xi \cdot \hat{e}_\xi) \quad (20)$$

where  $T'_{M,E}$  is equal to  $T_{M,E}/S_d$ .

Equation (20) together with (13) lead to

$$\vec{E}_d(\psi, \xi, n) = C_f \sqrt{G_f(\psi, n)} \cos \psi \frac{e^{-jkL(\psi)}}{F+d} \vec{P}'_d(\psi, \xi) \quad (21)$$

where the divergence factor  $1/\rho''(\psi)$  is approximated by  $\cos \psi/(F+d)$  and  $L(\psi)$  is given by

$$L(\psi) = \frac{F}{\cos \psi} + \frac{\epsilon_r d}{\sqrt{\epsilon_r - \sin^2 \psi}} \quad (22)$$

Thus, (21) gives the vector field distribution over the dielectric-zone apertures after taking into account the amplitude, phase and polarization changes due to the multiple transmission (refraction) process.

Referring to Fig. 5 and (9) it is not difficult to write a similar expression for the vector field distribution over the open-zone apertures

$$\vec{E}_0(\psi, \xi, n) = C_f \sqrt{G_f(\psi, n)} \cos \psi \frac{e^{-jkL_0(\psi)}}{F+d} \cdot \hat{e}_f(\psi, \xi) \quad (23)$$

with

$$L_0(\psi) = (F+d)/\cos \psi \quad (24)$$

##### B. Vectorial Far-Field Equations

For the classical FZPA with alternate opaque and transparent zones, the vectorial far-field equations have been derived in detail by means of Kirchhoff's diffraction theory in [6], and for the FZPA with phase-reversing dielectric rings these far-field equations have been modified heuristically in [9] by inclusion of the multiple transmission coefficients  $T_M$  and  $T_E$  in the field polarization vector.

Following the above publications and [10], a more precise and detailed far-field analysis for the FZPA with phase-shifting dielectric rings will be presented here.

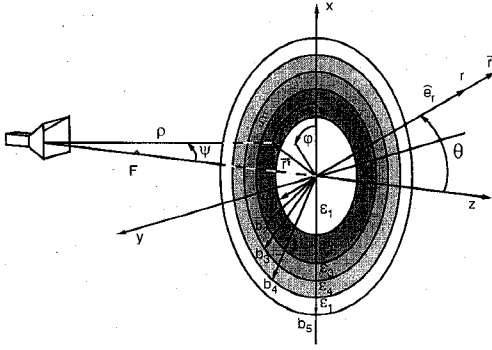

Fig. 7. Geometry of the Fresnel-zone plate antenna with phase-correcting dielectric rings.

Kirchhoff's diffraction integral for the vectorial far field can be written as follows

$$\vec{E}_d(\vec{r}) = C(r)\hat{e}_r(\varphi, \theta) \times \int \int_{A''} [\hat{n} \times \vec{P}'_d(\psi, \xi)] \cdot \cos \psi \frac{\sqrt{G_f(\psi, n)}}{F+d} e^{-jkL(\psi)} e^{jk\hat{e}_r \cdot \vec{r}''} dA'' \quad (25)$$

where

$$C(r) = j \frac{ke^{-jkr}}{2\pi r} \sqrt{\frac{P_f Z_0}{2\pi}} \quad (26)$$

and the normal unit-vector  $\hat{n}$  is oriented along the  $z$ -axis, i.e.  $\hat{n} = \hat{e}_z$ , and  $\hat{e}_r$  is the unit vector in the  $r$  direction (Fig. 7).

The vector components of  $\hat{n} \times \vec{P}'_d(\psi, \xi)$  in the Cartesian  $(x, y, z)$  coordinate system are

$$\hat{n} \times \vec{P}'_d(\psi, \xi) = \begin{pmatrix} (T'_M \cos \psi - T'_E) \sin \xi \cos \xi \\ -T'_M \cos^2 \xi \cos \psi - T'_E \sin^2 \xi \\ 0 \end{pmatrix}. \quad (27)$$

The unit-vector  $\hat{e}_r(\varphi, \theta)$  points to a far-field observation point and its vector components are given by

$$\hat{e}_r(\varphi, \theta) = \begin{pmatrix} \sin \theta \cos \varphi \\ \sin \theta \sin \varphi \\ \cos \theta \end{pmatrix}. \quad (28)$$

The vector  $\vec{r}'$  defines a point on the input plane  $I - I'$  and can be written as

$$\vec{r}' = \begin{pmatrix} F \tan \psi \cos \xi \\ F \tan \psi \sin \xi \\ 0 \end{pmatrix}. \quad (29)$$

The vector  $\vec{r}''$  defines a point on the output (aperture) plane  $II - II'$  and can be expressed as follows

$$\vec{r}'' = \begin{pmatrix} (F \tan \psi + \frac{d \sin \psi}{\sqrt{\epsilon_r - \sin^2 \psi}}) \cos \xi \\ (F \tan \psi + \frac{d \sin \psi}{\sqrt{\epsilon_r - \sin^2 \psi}}) \sin \xi \\ 0 \end{pmatrix}. \quad (30)$$

For the aperture element  $dA''$  the next equation was found [10]

$$dA'' = \left[ \frac{F}{\cos^2 \psi} + \frac{\epsilon_r d \cos \psi}{(\epsilon_r - \sin^2 \psi)^{3/2}} \right] \cdot \left[ F \tan \psi + \frac{d \sin \psi}{\sqrt{\epsilon_r - \sin^2 \psi}} \right] d\xi d\psi. \quad (31)$$

The scalar product in the phase factor  $e^{jk\hat{e}_r \cdot \vec{r}''}$  is given by

$$\hat{e}_r \cdot \vec{r}'' = \sin \theta \left( F \tan \psi + \frac{d \sin \psi}{\sqrt{\epsilon_r - \sin^2 \psi}} \right) \cos(\varphi - \xi). \quad (32)$$

Setting

$$M_d(\psi) = -jkL(\psi) \quad (33)$$

$$N_d(\theta, \psi) = k \sin \theta \left( F \tan \psi + \frac{d \sin \psi}{\sqrt{\epsilon_r - \sin^2 \psi}} \right) \quad (34)$$

$$e^{jk\hat{e}_r \cdot \vec{r}''} = e^{jN_d(\theta, \psi) \cos(\varphi - \xi)} \quad (35)$$

and

$$O_d(\psi, n) = \sqrt{G_f(\psi, n)} \frac{\cos \psi}{F+d} \left[ \frac{F}{\cos^2 \psi} + \frac{\epsilon_r d \cos \psi}{(\epsilon_r - \sin^2 \psi)^{3/2}} \right] \cdots \left[ F \tan \psi + \frac{d \sin \psi}{\sqrt{\epsilon_r - \sin^2 \psi}} \right] \quad (36)$$

the Kirchhoff integral formula for the far-field vector  $\vec{E}_d(\vec{r})$  can be represented in the following form

$$\vec{E}_d(\vec{r}) = C(r)\hat{e}_r(\varphi, \theta) \times \int_0^{2\pi} \begin{pmatrix} (T'_M \cos \psi - T'_E) \sin \xi \cos \xi \\ -T'_M \cos^2 \xi \cos \psi - T'_E \sin^2 \xi \\ 0 \end{pmatrix} \cdots O_d(\psi, n) e^{M_d(\psi)} e^{jN_d(\theta, \psi) \cos(\varphi - \xi)} d\psi d\xi. \quad (37)$$

After performing the  $\xi$ -integration in a closed form, the vector components in the spherical  $(r, \theta, \varphi)$  coordinate system of the far-field  $\vec{E}_d(\vec{r})$  due to all dielectric zone apertures are given by

$$E_\theta^{(d)}(r, \theta, \varphi) = -\pi C(r) \cos \varphi \sum_m \int_{\psi_m}^{\psi_{m+1}} O_d(\psi, n) e^{M_d(\psi)} I_\theta^{(d)}(\theta, \psi) d\psi \quad (38)$$

$$E_\varphi^{(d)}(r, \theta, \varphi) = -\pi C(r) \sin \varphi \cos \theta \sum_m \int_{\psi_m}^{\psi_{m+1}} O_d(\psi, n) e^{M_d(\psi)} I_\varphi^{(d)}(\theta, \psi) d\psi \quad (39)$$

where

$$I_\theta^{(d)}(\theta, \psi) = -(T'_M \cos \psi + T'_E) J_0[N_d(\theta, \psi)] + (T'_M \cos \psi - T'_E) J_2[N_d(\theta, \psi)] \quad (40)$$

and

$$I_\varphi^{(d)}(\theta, \psi) = (T'_M \cos \psi + T'_E) J_0[N_d(\theta, \psi)] + (T'_M \cos \psi - T'_E) J_2[N_d(\theta, \psi)]. \quad (41)$$

The far-field components of the open radiating apertures are the same as those given in [6], with  $F$  replaced by  $F+d$

$$E_\theta^{(0)}(r, \theta, \varphi) = -\pi C(r) \cos \varphi \sum_{m'} \int_{\psi_{m'}}^{\psi_{m'+1}} O(\psi, n) e^{M(\psi)} I_\theta(\theta, \psi) d\psi \quad (42)$$

TABLE II  
RADIATION CHARACTERISTICS OF THREE FRESNEL-ZONE PLATE ANTENNA TYPES

Fresnel-zone plate antenna type	Directive gain (dBi)	Sidelobe level (dB)	Aperture efficiency (%)
(I) Quarter-wave FPZA	36.6	-30.7	51.7
(II) Half-wave FZPA	34.5	-22.0	30.4
(III) Classical FZPA	30.1	-16.0	11.1

$$E_{\varphi}^{(0)}(r, \theta, \varphi) = -\pi C(r) \sin \varphi \cos \theta \sum_{m'} \int_{\psi_{m'}}^{\psi_{m'+1}} O(\psi, n) e^{M(\psi)} I_{\varphi}(\theta, \psi) d\psi \quad (43)$$

where

$$O(\psi, n) = \sqrt{G_f(\psi, n)} \frac{(F+d) \tan \psi}{\cos \psi} \quad (44)$$

$$M(\psi) = -jk \frac{F+d}{\cos \psi} \quad (45)$$

$$N(\theta, \psi) = k(F+d) \sin \theta \tan \psi \quad (46)$$

$$I_{\theta}(\theta, \psi) = -(\cos \psi + 1) J_0[N(\theta, \psi)] + (\cos \psi - 1) J_2[N(\theta, \psi)] \quad (47)$$

$$I_{\varphi}(\theta, \psi) = (\cos \psi + 1) J_0[N(\theta, \psi)] + (\cos \psi - 1) J_2[N(\theta, \psi)]. \quad (48)$$

In the case of the quarter-wave FZPA

$$\begin{cases} m' = 0, 4, 8, \dots & \text{for subzones with } \epsilon_r = 1.00 \\ m' = 1, 5, 9, \dots & \text{for subzones with } \epsilon_r = 6.25 \\ m' = 2, 6, 10, \dots & \text{for subzones with } \epsilon_r = 4.00 \\ m' = 3, 7, 11, \dots & \text{for subzones with } \epsilon_r = 2.25 \end{cases} \quad (49)$$

and for the half-wave FZPA

$$\begin{cases} m' = 0, 2, 4, \dots & \text{for subzones with } \epsilon_r = 1.00 \\ m' = 1, 3, 5, \dots & \text{for subzones with } \epsilon_r = 4.00 \end{cases} \quad (50)$$

Finally, the total scalar far-field components  $E_{\theta}(r, \theta, \varphi)$  and  $E_{\varphi}(r, \theta, \varphi)$  can be found

$$E_{\theta}(r, \theta, \varphi) = E_{\theta}^{(0)}(r, \theta, \varphi) + E_{\theta}^{(d)}(r, \theta, \varphi) \quad (51)$$

$$E_{\varphi}(r, \theta, \varphi) = E_{\varphi}^{(0)}(r, \theta, \varphi) + E_{\varphi}^{(d)}(r, \theta, \varphi) \quad (52)$$

or in a vectorial form, the electric far-field can be written as follows

$$\vec{E}(r, \theta, \varphi) = E_{\theta}(r, \theta, \varphi) \cdot \hat{e}_{\theta} + E_{\varphi}(r, \theta, \varphi) \cdot \hat{e}_{\varphi}. \quad (53)$$

### C. Antenna Radiation Properties

In Table II, the main radiation characteristics of the quarter-wave FZPA design (I) are compared to those of an Fresnel antenna comprising a lens with phase-reversing dielectric rings (II), and with those of the classical Fresnel lens (III), comprising a lens with alternate transparent and opaque zones. All of them are 150 mm in diameter, 132 mm in focal length, and have an edge illumination level of  $-12$  dB. The zone rings were supposed to be made of a dielectric material with  $\tan \delta = 0.0001$ . Their radii  $b_m$  and a thickness  $d$  were calculated using (2) and (7), respectively.

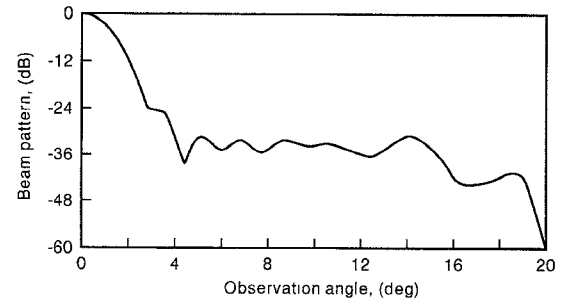

Fig. 8. Beam pattern of quarter-wave Fresnel-zone plate antenna.

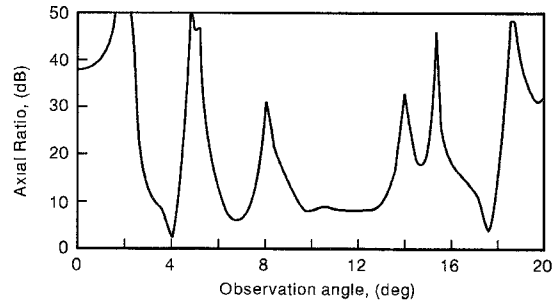

Fig. 9. Axial polarization ratio AR versus observation angle.

From Table II it is concluded that for the same antenna dimensions and design parameters the quarter-wave FZPA version with a directive gain of 36.6 dBi and an efficiency of 51.7% surpasses 2.1 dB in gain and about 1.7 times in efficiency the half-wave FZPA, and 6.5 dB in gain and about 4.5 times in efficiency the classical FZPA.

The theoretical values for the antenna efficiency agree with the measured overall antenna efficiencies reported by other researchers for similar reflector-type FZPA's, namely 26% for an half-wave FZPA at 94 GHz [11], and 43% for an X-band quarter-wave FZPA [12].

Fig. 8 shows the co-polar radiation pattern of the analysed quarter-wave FZPA computed at a frequency of 62.1 GHz. In Fig. 9 the polarization axial ratio AR at the  $\varphi = 45^\circ$  far-field plane is given as a function of the observation angle  $\theta$ . In the  $\varphi = 45^\circ$  plane the far-field has a maximum cross-polar component, but even in this plane the axial ratio is larger than 35 dB in the main lobe region, i.e., the depolarization introduced by the quarter-wave lens consisting of rings with different permittivities is tolerable for most applications.

The calculated directive gain and antenna efficiency of the antenna under examination as a function of frequency are shown in Fig. 10. The 3 dB bandwidth of the antenna gain due to the frequency-dependent properties of the lens is about 22%.

## V. CONCLUSION

A multielectric planar quarter-wave Fresnel-zone plate lens for millimeter waves with improved focusing quality was proposed and designed. More practical equations for the radii of the Fresnel zones were derived, by taking into account the thickness of the lens. It was indicated that the thickness of the

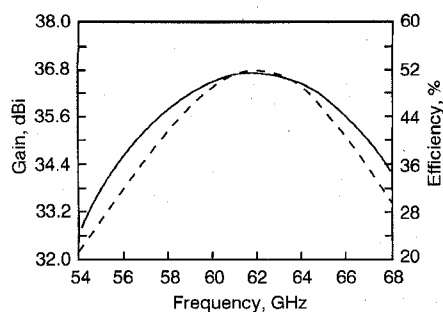

Fig. 10. Directive gain (solid line) and antenna efficiency (dashed line) versus frequency.

lens depends on the angle of incidence of the wave originating from the feed which illuminates the lens.

Based on the new lens configuration, a millimeter-wave Fresnel-zone plate antenna (FZPA) with more than 50% efficiency was described. This antenna was examined theoretically by means of multiple ray tracing techniques and vectorial Kirchhoff diffraction theory.

The computed aperture efficiency values for this transmissive-type FZPA agree with measured overall antenna efficiencies reported by other researchers for similar reflector-type FZPA's.

#### REFERENCES

- [1] J. C. Wiltse, "Private communication," 1976.
- [2] ———, "The Fresnel zone-plate lens," *SPIE*, vol. 44, *Millimeter Wave Technol. II*, pp. 41–47, 1985.
- [3] D. N. Black and J. C. Wiltse, "Millimeter-wave characteristics of phase-correcting Fresnel zone plates," *IEEE Trans. Microwave Theory Tech.*, vol. 35, no. 12, pp. 1122–1128, 1987.
- [4] M. J. Lazarus, A. Silvertown, and S. Novak, "Fresnel zone plate aids low-cost Doppler design," *Microwaves*, no. 11, pp. 78–80, 1979.
- [5] H. D. Hristov, J. R. Urumov, and M. J. Semov, "Ring-shaped dielectric antenna," *Proc. 1980 European Microwave Conf.*, Warsaw, Sept. 1980, pp. 109–113 (also in: *Advanced Antenna Technology*, Ed. P. J. B. Clarricoats, reprint, vol. 1, *Conf. Exhibitions & Publishers Ltd.*, UK, 1982, pp. 361–365).
- [6] L. Leyten and M. H. A. J. Herben, "Vectorial far-field analysis of the Fresnel zone plate antenna: A comparison with the parabolic reflector antenna," *Microwave and Optical Technol. Lett.*, vol. 5, no. 2, pp. 49–56, 1992.
- [7] Y. J. Guo and S. K. Barton, "A high efficiency quarter-wave zone plate reflector," *IEEE Microwave and Guided Wave Letters*, vol. 2, no. 12, pp. 470–471, Dec. 1992.
- [8] ———, "Multilayer phase correcting Fresnel zone plate reflector antennas," *Int. J. Satellite Commun.*, vol. 11, pp. 75–80, Nov. 1993.
- [9] J. M. van Houten and M. H. A. J. Herben, "Analysis of phase-correcting Fresnel zone antenna with dielectric/transparent zones," *J. Electromagnetic Waves Applicat.*, vol. 8, no. 7, pp. 847–858, 1994.

- [10] H. D. Hristov, "Analysis and design of transmissive Fresnel zone antennas for DBS reception," Research Report on CEC Contract/CIPA 3510-CT926503/1993, Telecommunications Division, Eindhoven Univ. of Technology, Feb. 1994, (72 pp.).
- [11] B. Huder and W. Mentzel, "Flat printed reflector antenna for mm-wave applications," *Electron. Lett.*, vol. 24, no. 6, pp. 318–319, 1988.
- [12] Y. J. Guo and S. K. Barton, "Phase correcting zonal reflector incorporating rings," *IEEE Trans. Antennas Propagat.*, vol. 43, pp. 350–355, 1995.

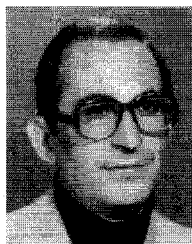

**Hristo D. Hristov** (SM'87) received the M.Eng., Ph.D. and D.Sc. degrees in radio communications engineering from the Technical University of Sofia, Bulgaria, in 1963, 1973, and 1987, respectively.

Since 1965 he has been with the Technical University of Varna, Bulgaria, where he is now Professor in the Department of Radiotechnics. His research interests have been mainly in high-frequency electromagnetics, antennas, microwave, and quasi-optical devices and systems. From 1971 to 1972 he specialized in electromagnetics at Strathclyde University, Glasgow, and from 1975 to 1976 he was the Leverhulme Fund Visiting Research Fellow at Queen Mary College, London, UK, where he was engaged with backfire antenna research. He was short-term Visiting Fellow at the St. Petersburg Electrotechnical University in 1982, Russia and the Technical University of Athens, Greece in 1983, and also Visiting Professor at the Tsukuba University, Japan in 1990 and the Aalborg University Center, Denmark in 1993. In 1993 he was granted a contract for three months from the European COST Telecommunications Division (CEC-Brussels) for doing research at Eindhoven University of Technology, The Netherlands. He is a co-author, with Dr. A. Kumar, of the book *Microwave Cavity Antennas*, (Artech House, 1989).

Dr. Hristov was invited lecturer at Tokyo AP-S Chapter in 1990, Sweden AP/MTT-S Chapter in 1993, and European Space Technology Center (ESA/ESTEC-1993). He served as a co-organizer of Bulgaria IEEE Section and MTT/ED-S Chapter.

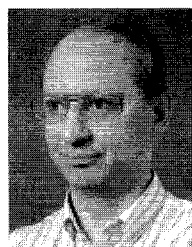

**Mathieu H. A. J. Herben** (SM'88) was born in Klundert, The Netherlands, in 1953. He received the M.Sc. degree (with distinction) in electrical engineering in 1978 and the Ph.D. degree in technical sciences in 1984, both from Eindhoven University of Technology (EUT), Eindhoven, The Netherlands.

Since 1978 he is employed at the Telecommunications Division of EUT, at present as an Associate Professor. His research interests and publications are in the areas of design and numerical analysis of reflector and lens antenna systems, radio interference reduction, electromagnetic wave propagation on terrestrial and satellite links, remote sensing of the turbulent troposphere, and microwave radiometry.

Dr. Herben is Associate Editor of *Radio Science*, a member of the Institute of Dutch Engineers (KIVI), The Netherlands Electronics and Radio Society (NERG), and the Dutch URSI-Committee.